

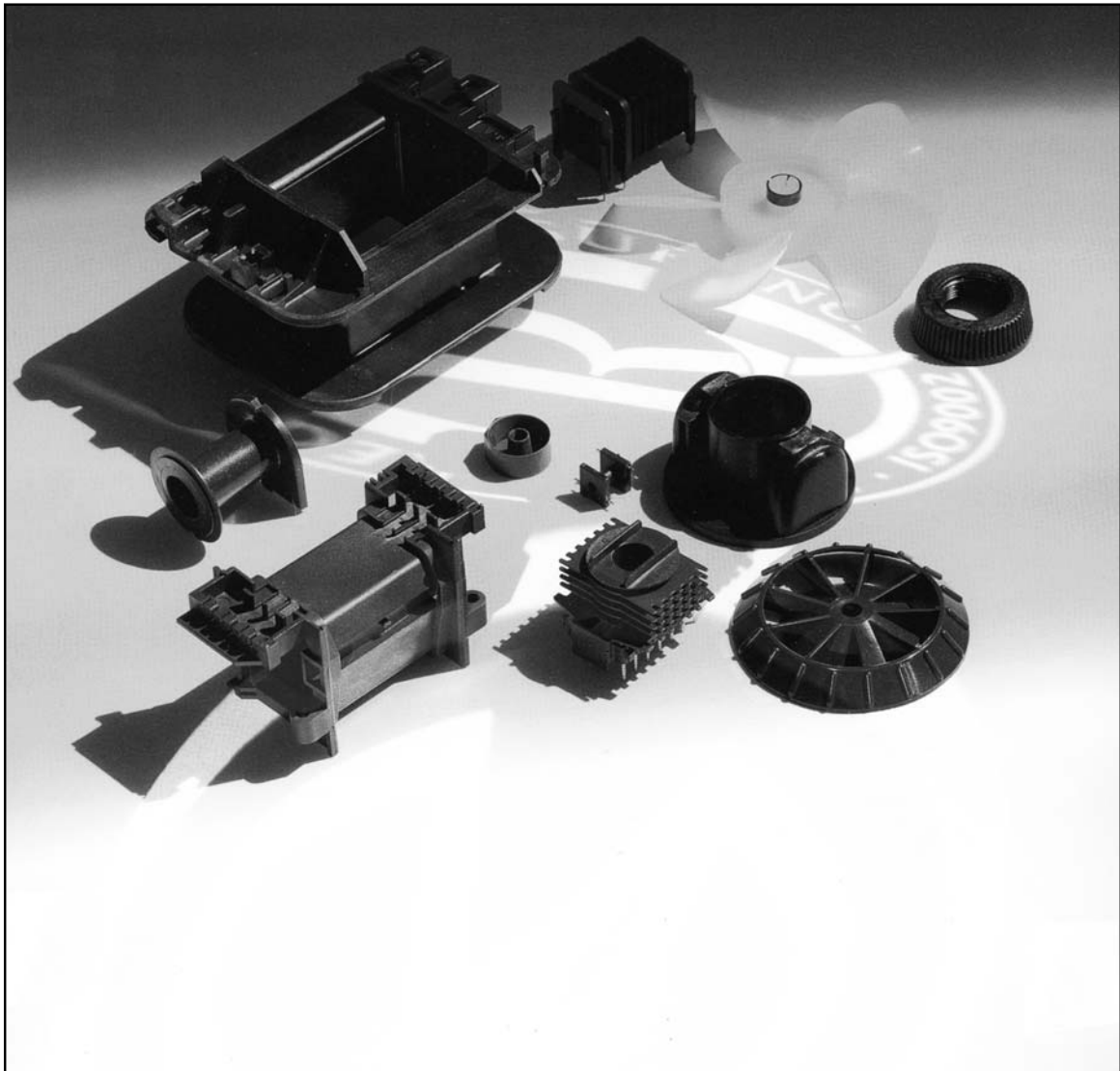

CUSTOM & MISCELLANEOUS

MILES · PLATTS

- Design service available
- Product and material consultancy
- Unique modular tooling
- Advanced moulding technology for optimum yields
- Rapid prototype service available
- Custom technical mouldings
- Round wire, square wire and pressed terminals available
- Custom solutions achieved within short time scales



Most products are available direct from stock with same day despatch
- please contact sales for details



MILES · PLATTS

Coil Formers Miscellaneous

**GAS IGNITION - 3 CHAMBER
Ø9.0 BORE**

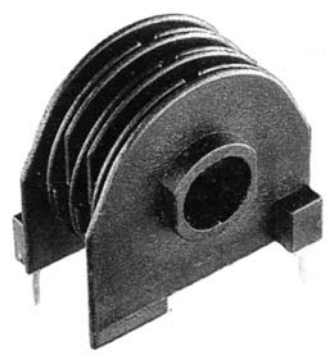
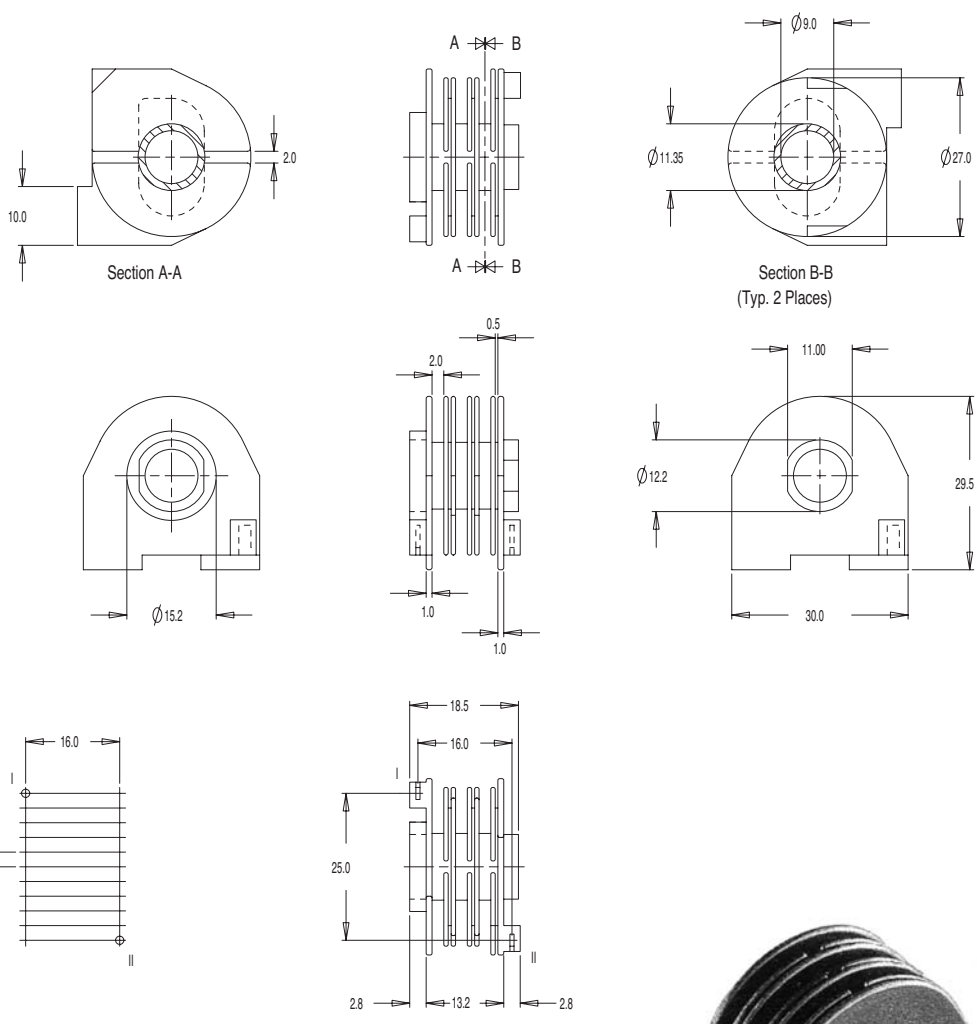

Section 7

Description	Type	Terminal type	No. of terminals available	Part No.
Gas Ignition	3 chamber	TBS 600 series	2	G16500

Standard materials: Nylon 66 glass reinforced Dimensions in millimetres

Miles-Platts terminals & wire pins are lead-free - all polymers meet the ROHS directive (2002/95/EC). Please refer to website for details.

Section 7
2



MILES · PLATTS

Coil Formers Miscellaneous

**GAS IGNITION - 4 CHAMBER
Ø9.0 BORE**

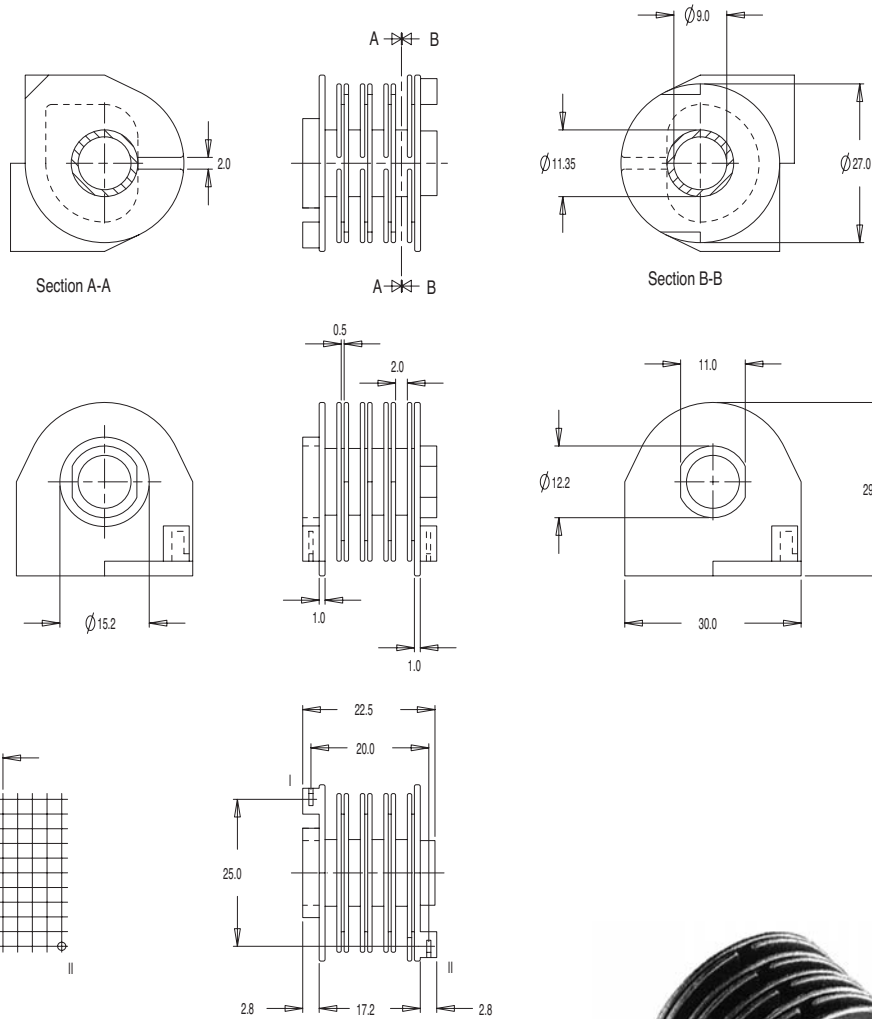

Description	Type	Terminal type	No. of terminals available	Part No.
Gas Ignition	4 chamber	TBS 600 series	2	GI6510

Standard materials: Nylon 66 glass reinforced Dimensions in millimetres

Miles-Platts are technical moulders - we manufacture more than bobbins
- please contact sales for details

Section 7



Coil Formers Miscellaneous

MILES · PLATTS

5001

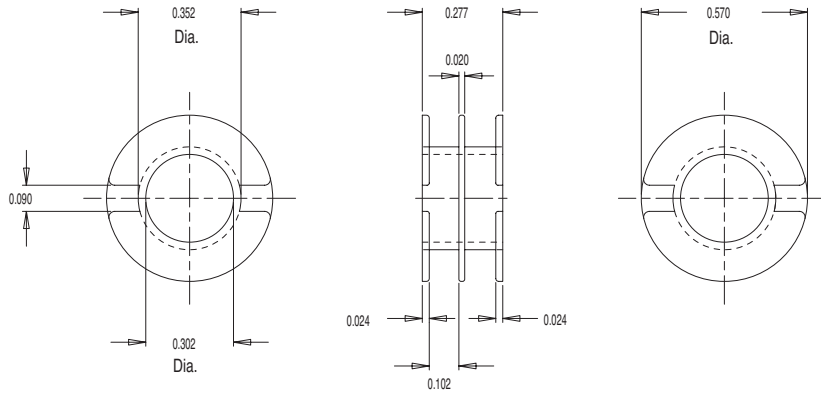

Description	Type	Terminal type	No. of terminals available	Part No.
5001	DS	-	-	VM1200

Standard materials: Nylon 66 glass reinforced
Dimensions in inches

SOLENOID BOBBINS

Miles-Platts hold particular expertise in the manufacture of solenoid bobbins for a variety of industries including automotive, medical, industrial, commercial & vending.

As each bobbin is customer specific and designed specifically for the individual application it is not possible to show all of the products here.

For further details on solenoid bobbin design please refer to sales@milesplatts.co.uk

The following bobbins are standard products.

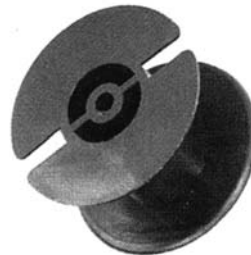
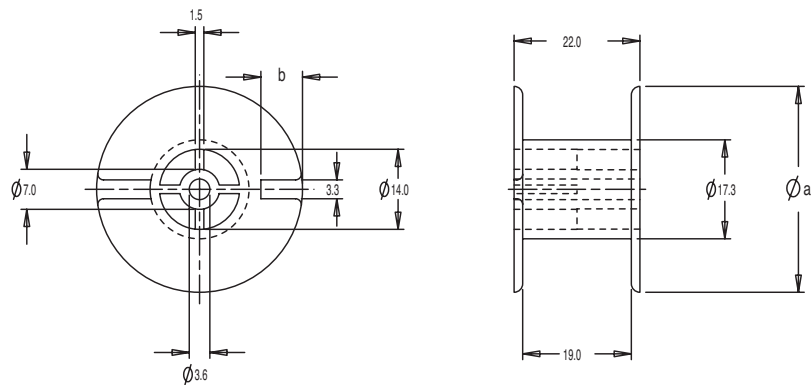

Bobbin type	ϕa	b	Part No.
4275 SOLENOID A	35.5	9.1	VM1100
4275 SOLENOID B	50.4	6.5	VM1101
4275 SOLENOID C	69.5	6.5	VM1102

Standard materials: Nylon 66 Dimensions in millimetres

For further technical information please contact sales@milesplatts.co.uk or www.milesplatts.co.uk

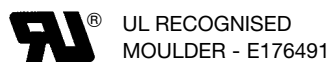

Section 7
4



Coil Formers Miscellaneous

MILES · PLATTS

FANS

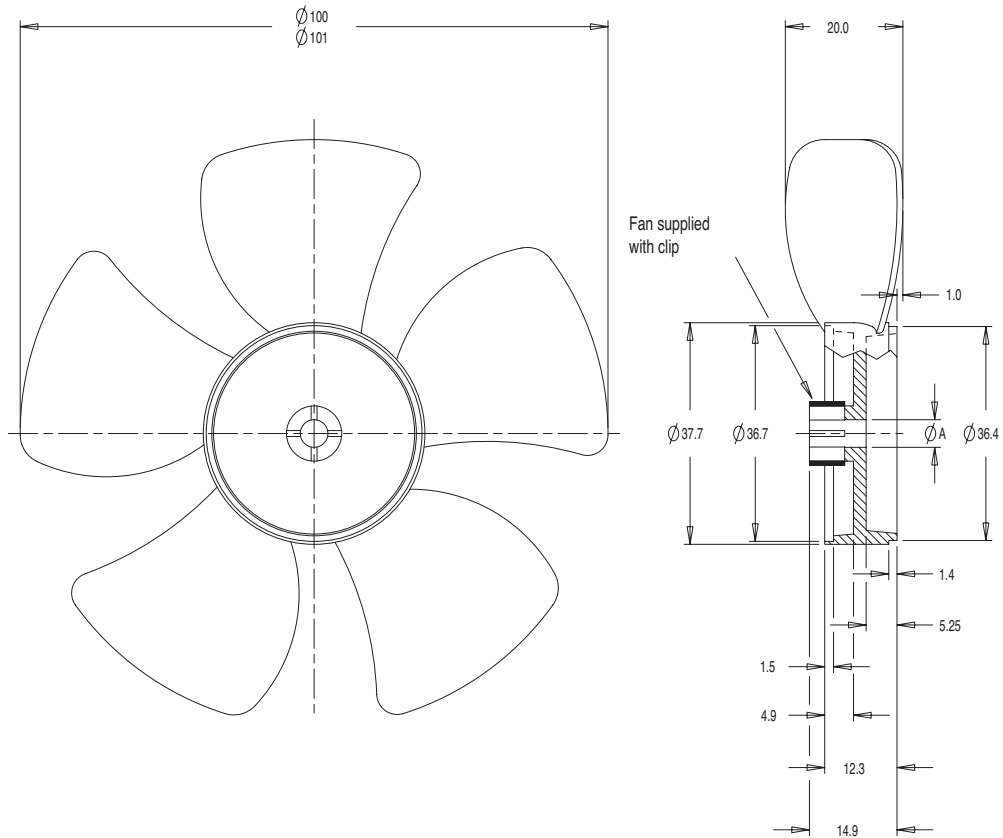

Description	Bore Dia. A	Part No.
Fan	3.5	VM4610
Fan	3.85	VM4620
Fan	4.7	VM4630
Fan	4.5	VM4640

Standard materials: Nylon 66 Dimensions in millimetres

For further technical information please contact sales
 Tel: +44 (0) 116 262 2593 Fax: +44 (0) 116 253 7889

Section 7



EI Ferrite Core Coil Formers

MILES · PLATTS

EI 3530

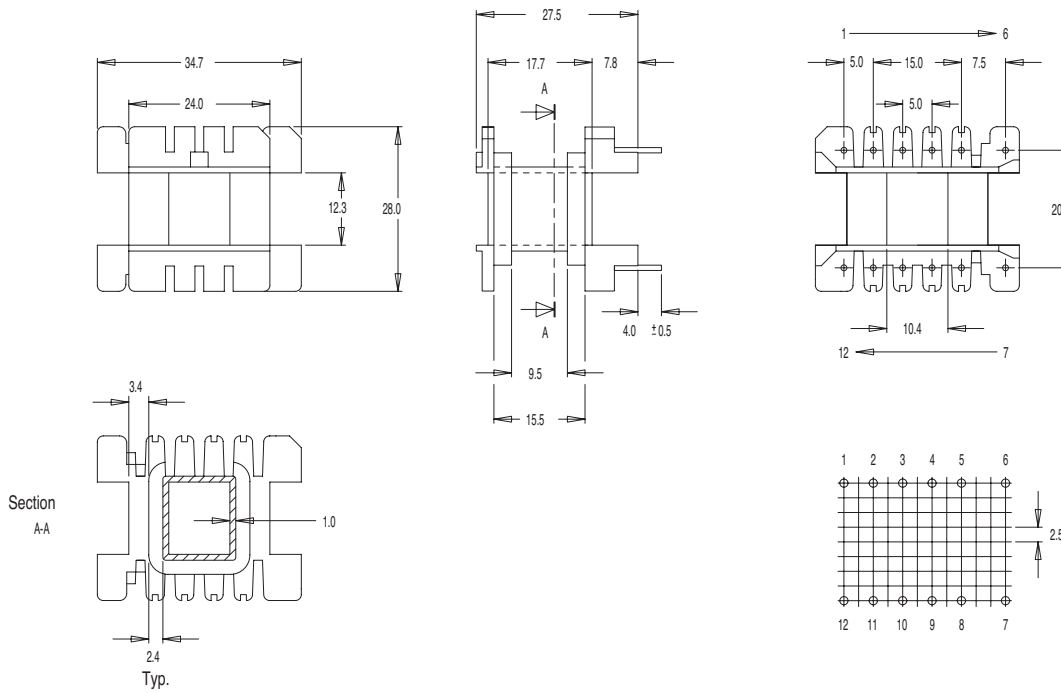

Section 7

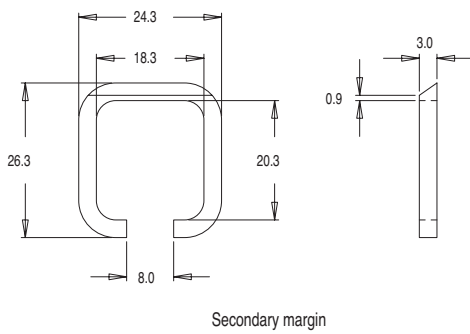

Bobbin size	Type/Description	No. of pins available	Pin size	Part No.
EI 3530	SS With primary margin	12 (2 x 6)	Ø0.9	VM0700
EI 3530	Secondary margin	-	-	VM0701

Standard materials: Nylon 66 glass reinforced to UL94V0 Pin material: Half Hard Brass Dimensions in millimetres

Most products are available direct from stock with same day despatch
- please contact sales for details

Section 7
6

