

Ferrite for Telecommunication SMD Cores

ORDERING CODE SYSTEMS

1. Cores

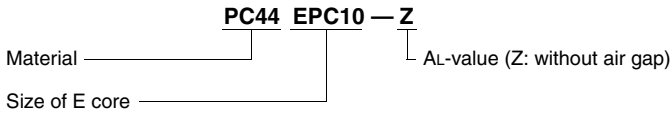

2. Bobbins

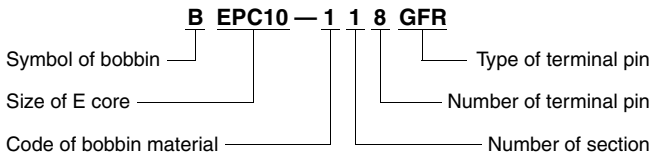

3. Accessories

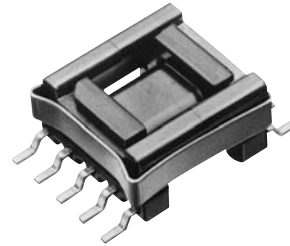
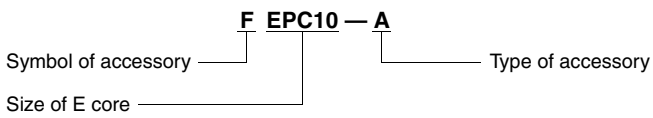

METHOD OF ASSEMBLING

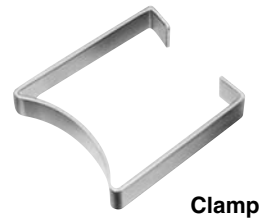
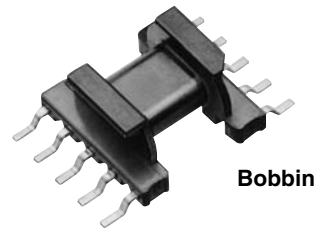
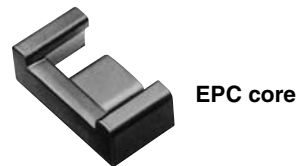

EPC10 CORES

CORES

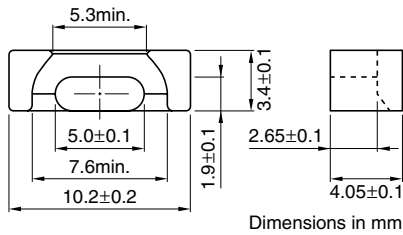

Dimensions in mm

Parameter

Core factor	C ₁	mm ⁻¹	1.89
Effective magnetic path length	ℓ _e	mm	17.8
Effective cross-sectional area	A _e	mm ²	9.39
Effective core volume	V _e	mm ³	167
Cross-sectional center pole area	A _{cp}	mm ²	8.73
Minimum cross-sectional area	A _{cp min.}	mm ²	8.13
Cross-sectional winding area of core	A _{cw}	mm ²	7.69
Weight (approx.)		g	1.1

TYPICAL CHARACTERISTICS

Part No.	AL-value (nH/N ²) [1kHz, 0.5mA, 100Ts]		Core loss (W) [at 100°C]	
	Without air gap	With air gap	100kHz 200mT	500kHz 50mT
PC44EPC10-□□□*1	1000±25%	40±7% 63±10%	0.072	
PC50EPC10-□□□	660±25%	40±7% 63±10%	0.025	
H5C3EPC10-Z*2	2660 min.			

*1 Including AL-value

*2 10kHz, 10mV, 100Ts

BOBBINS

BEPC10-118GAFR

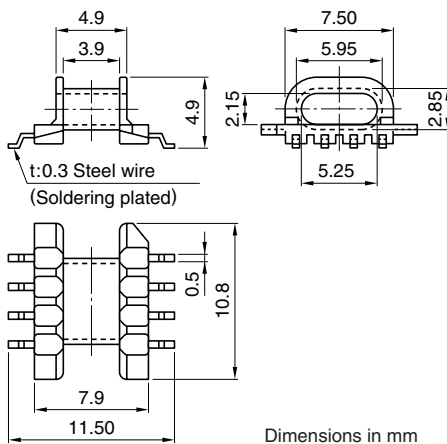

Dimensions in mm

CONNECTING PIN PATTERNS

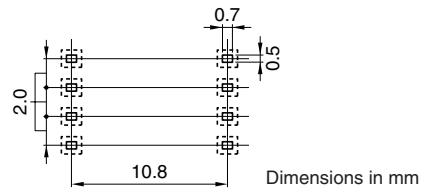

Dimensions in mm

Part No.	Material	Heat deflection temperature (°C)*1	UL standard	Available winding cores section A _w (mm ²)	Average length of turns ℓ _w (mm)	Minimum thickness t(mm) ^j *2	Weight (g)
BEPC10-118GAFR	FR phenol	235	94V-0	3.2	17.5	0.35	0.14

*1 With 18.6kg/cm² force

*2 Minimum thickness of bobbin

ASSEMBLY

SURFACE MOUNT TYPE

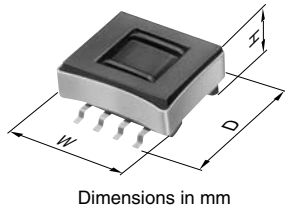

Dimensions in mm

W	11.0
D	11.7
H	5.2

ACCESSORIES

CLAMP

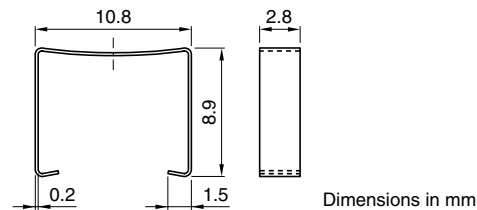

Dimensions in mm

Part No.	Material	Weight (g)
FEPC-10-A	Stainless steel	0.1

EPC13 CORES

CORES

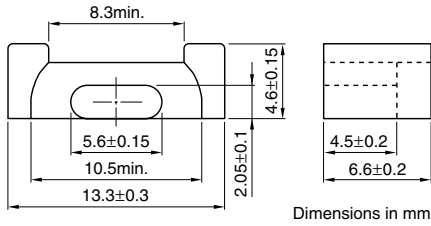

TYPICAL CHARACTERISTICS

Part No.	AL-value(nH/N ²) [1kHz, 0.5mA, 100Ts]		Core loss (W) [at 100°C]	
	Without air gap	With air gap	100kHz 200mT	500kHz 50mT
PC44EPC13-□□□*1	870±25%	40±4% 63±5%	0.14	
PC50EPC13-□□□	560±25%	40±4% 63±5%	0.039	
H5C3EPC13-Z*2	2450 min.			

*1 Including AL-value
*2 10kHz, 10mV, 100Ts

Parameter

Core factor	C ₁	mm ⁻¹	2.46
Effective magnetic path length	ℓ _e	mm	30.6
Effective cross-sectional area	A _e	mm ²	12.5
Effective core volume	V _e	mm ³	382
Cross-sectional center pole area	A _{cp}	mm ²	10.6
Minimum cross-sectional area	A _{cp min.}	mm ²	9.71
Cross-sectional winding area of core	A _{cw}	mm ²	23.0
Weight (approx.)		g	2.1

BOBBINS

BEPC13-1110GAFR

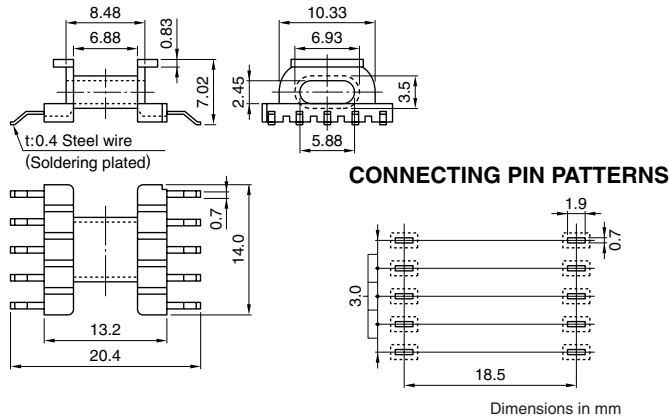

BEPC13-1110CPHFR

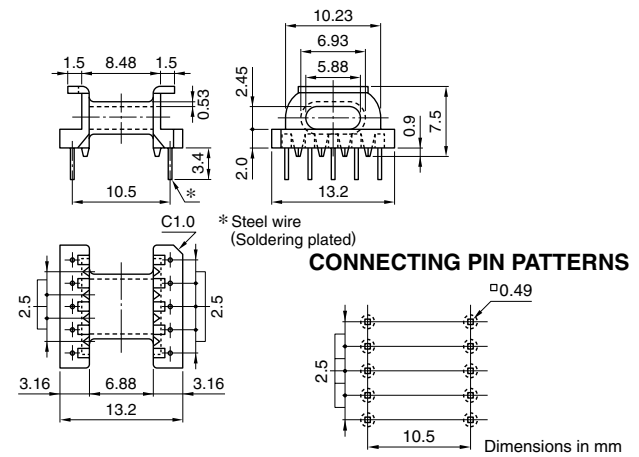

Part No.	Material	Heat deflection temperature (°C)*1	UL standard	Available winding cores section Aw(mm ²)	Average length of turns ℓ _w (mm)	Minimum thickness t(mm)*2	Weight (g)
BEPC13-1110GAFR	FR phenol	195	94V-0	11.2	23.0	0.5	0.6
BEPC13-1110CPHFR	FR phenol	195	94V-0	11.2	23.0	0.5	0.57

*1 With 18.6kg/cm² force
*2 Minimum thickness of bobbin

ASSEMBLY

SURFACE MOUNT TYPE

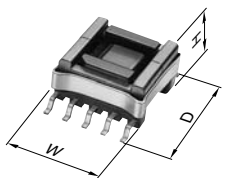

Dimensions in mm	
W	14.2
D	20.6
H	7.3

LEAD THROUGH TYPE

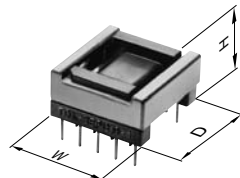

Dimensions in mm	
W	13.9
D	14.8
H	7.7

ACCESSORIES

CLAMP

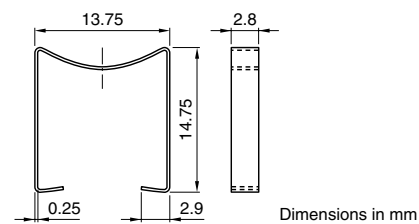

Part No.	Material	Weight (g)
FEPC-13-A	Stainless steel	0.3

ER9.5/5 CORES

CORES

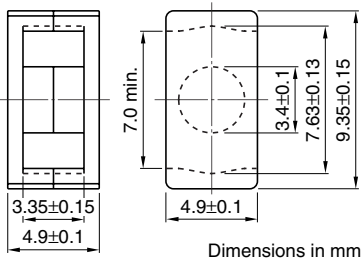

TYPICAL CHARACTERISTICS

Part No.	AL-value(nH/N ²) [1kHz, 0.5mA, 100Ts]		Core loss (W) [at 100°C]	
	Without air gap	With air gap	100kHz 200mT	500kHz 50mT
PC44ER9.5/5-□□□ *1	610 min.	63±5% 100±7%		
PC50ER9.5/5-□□□	750±25%	63±5% 100±7%		0.015
H5C3ER9.5/5-Z *2	3500 min.			

*1 Including AL-value

*2 10kHz, 10mV, 100Ts

BOBBINS

BER9.5/5-118GAFR

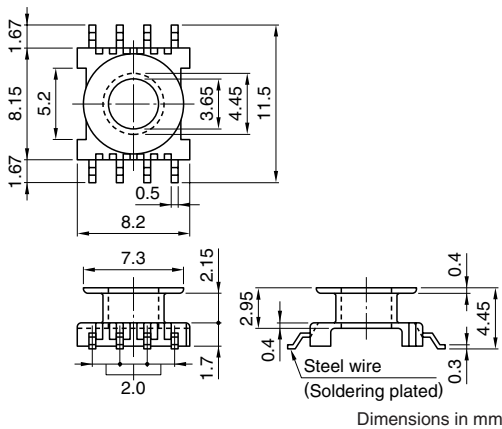

CONNECTING PIN PATTERNS

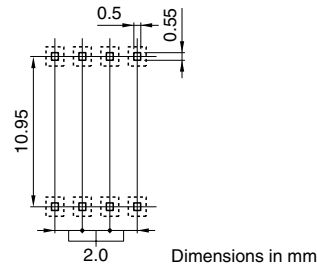

Part No.	Material	Heat deflection temperature (°C)*1	UL standard	Available winding cores section Aw(mm ²)	Average length of turns ℓ _w (mm)	Minimum thickness t(mm)*2	Weight (g)
BER9.5/5-118GAFR	FR phenol	235	94V-0	3.06	18.5	0.4	0.16

*1 With 18.6kg/cm² force

*2 Minimum thickness of bobbin

ASSEMBLY

SURFACE MOUNT TYPE

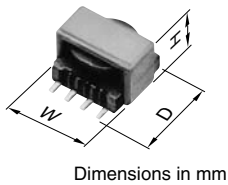

Dimensions in mm	
W	9.9
D	11.7
H	5.8

ACCESSORIES

CLAMP

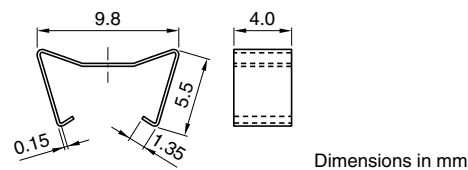

Part No.	Material	Weight (g)
FER9.5/5-A	Stainless steel	0.1

ER11/3.9 CORES

CORES

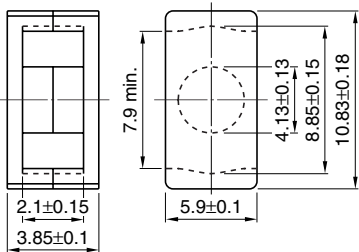

Dimensions in mm

Parameter

Core factor	C ₁	mm ⁻¹	1.08
Effective magnetic path length	ℓ _e	mm	12.6
Effective cross-sectional area	A _e	mm ²	11.7
Effective core volume	V _e	mm ³	147
Cross-sectional center pole area	A _{cp}	mm ²	13.4
Minimum cross-sectional area	A _{cp min.}	mm ²	12.6
Cross-sectional winding area of core	A _{cw}	mm ²	4.96
Weight (approx.)		g	0.8

TYPICAL CHARACTERISTICS

Part No.	AL-value(nH/N ²) [1kHz, 0.5mA, 100Ts]		Core loss (W) [at 100°C]	
	Without air gap	With air gap	100kHz 200mT	500kHz 50mT
PC44ER11/3.9-□□□*1	1040 min.	63±5% 100±7%		
PC50ER11/3.9-□□□	1100±25%	63±5% 100±7%		0.017
H5C3ER11/3.9-Z*2	4900 min.			

*1 Including AL-value

*2 10kHz, 10mV, 100Ts

BOBBINS

BER11/3.9-1110GAFR

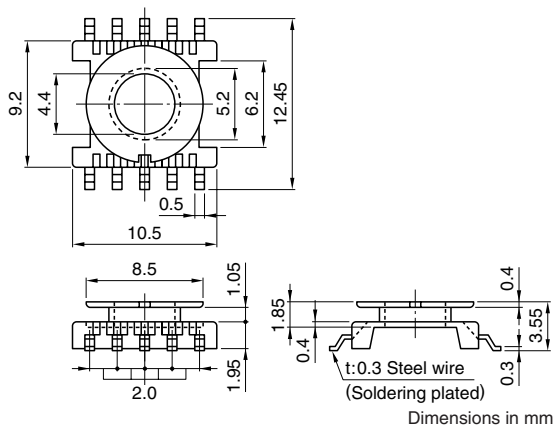

Dimensions in mm

CONNECTING PIN PATTERNS

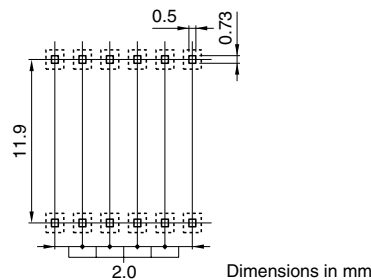

Dimensions in mm

Part No.	Material	Heat deflection temperature (°C)*1	UL standard	Available winding cores section A _w (mm ²)	Average length of turns ℓ _w (mm)	Minimum thickness t(mm)*2	Weight (g)
BER11/3.9-1110GAFR	FR phenol	235	94V-0	1.73	21.5	0.4	0.21

*1 With 18.6kg/cm² force

*2 Minimum thickness of bobbin

ASSEMBLY

SURFACE MOUNT TYPE

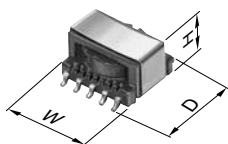

Dimensions in mm

W	11.0
D	12.6
H	4.7

ACCESSORIES

CLAMP

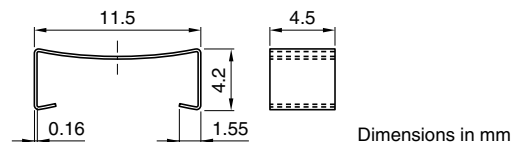

Dimensions in mm

Part No.	Material	Weight (g)
FER11/3.9-A	Stainless steel	0.13

ER11/5 CORES

CORES

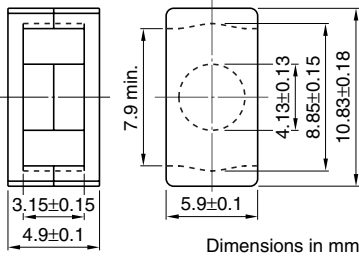

Dimensions in mm

Parameter

Core factor	C ₁	mm ⁻¹	1.23
Effective magnetic path length	ℓ _e	mm	14.7
Effective cross-sectional area	A _e	mm ²	11.9
Effective core volume	V _e	mm ³	174
Cross-sectional center pole area	A _{cp}	mm ²	13.4
Minimum cross-sectional area	A _{cp min.}	mm ²	12.6
Cross-sectional winding area of core	A _{cw}	mm ²	7.44
Weight (approx.)		g	1.0

TYPICAL CHARACTERISTICS

Part No.	AL-value(nH/N ²) [1kHz, 0.5mA, 100Ts]		Core loss (W) [at 100°C]	
	Without air gap	With air gap	100kHz 200mT	500kHz 50mT
PC44ER11/5-□□□*1	870 min.	63±5% 100±7%		
PC50ER11/5-□□□	960±25%	63±5% 100±7%		0.019
H5C3ER11/5-Z*2	4760 min.			

*1 Including AL-value

*2 10kHz, 10mV, 100Ts

BOBBINS

BER11/5-1110GAFR

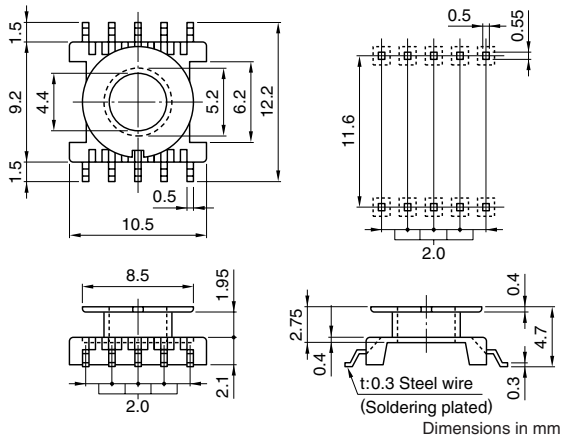

Dimensions in mm

CONNECTING PIN PATTERNS

BER11/5-118GAFR

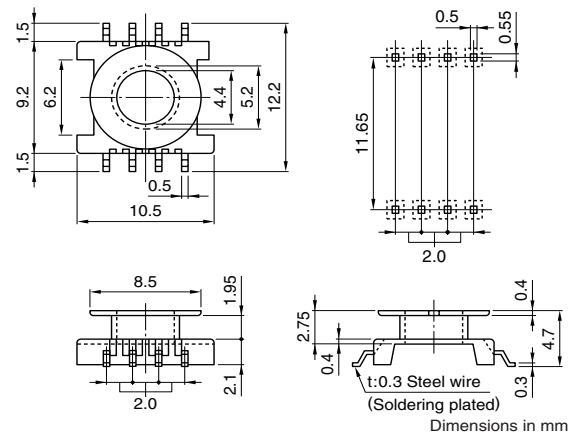

Dimensions in mm

Part No.	Material	Heat deflection temperature (°C)*1	UL standard	Available winding cores section A _w (mm ²)	Average length of turns ℓ _w (mm)	Minimum thickness t(mm)*2	Weight (g)
BER11/5-118GAFR	FR phenol	235	94V-0	3.22	21.5	0.4	0.21
BER11/5-1110GAFR	FR phenol	235	94V-0	3.22	21.5	0.4	0.21

*1 With 18.6kg/cm² force

*2 Minimum thickness of bobbin

ASSEMBLY

SURFACE MOUNT TYPE

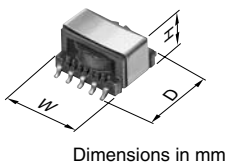

Dimensions in mm

W	11.5
D	12.3
H	6.4

ACCESSORIES

CLAMP

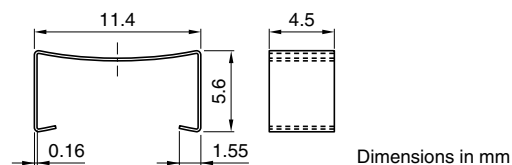

Dimensions in mm

Part No.	Material	Weight (g)
FER11/5-A	Stainless steel	0.13

ER14.5/6 CORES

CORES

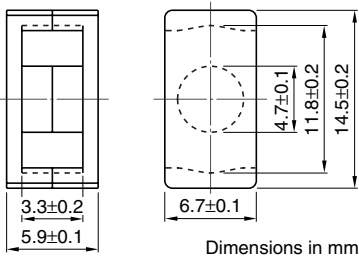

Parameter

Core factor	C ₁	mm ⁻¹	1.08
Effective magnetic path length	ℓ _e	mm	19.0
Effective cross-sectional area	A _e	mm ²	17.6
Effective core volume	V _e	mm ³	333
Cross-sectional center pole area	A _{cp}	mm ²	17.3
Minimum cross-sectional area	A _{cp min.}	mm ²	16.6
Cross-sectional winding area of core	A _{cw}	mm ²	11.7
Weight (approx.)		g	1.8

TYPICAL CHARACTERISTICS

Part No.	AL-value(nH/N ²) [1kHz, 0.5mA, 100Ts]		Core loss (W) [at 100°C]	
	Without air gap	With air gap	100kHz 200mT	500kHz 50mT
PC44ER14.5/6- □□□* ¹	1280 min.	100±5% 160±7%		
PC50ER14.5/6- □□□	1150±25%	100±5% 160±7%		0.044
H5C3ER14.5/6-Z * ²	5950 min.			

*1 Including AL-value

*2 10kHz, 10mV, 100Ts

BOBBINS

BER14.5/6-1110GAFR

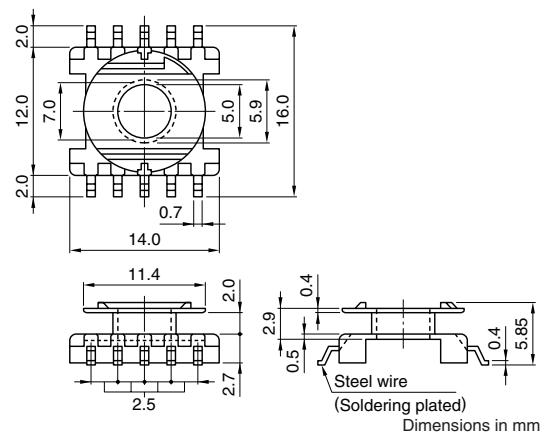

CONNECTING PIN PATTERNS

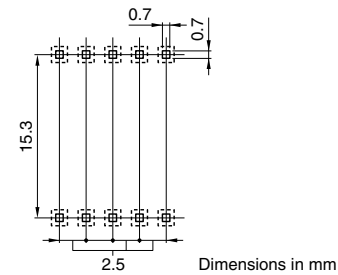

Part No.	Material	Heat deflection temperature (°C)* ¹	UL standard	Available winding cores section A _w (mm ²)	Average length of turns ℓ _w (mm)	Minimum thickness t(mm)* ²	Weight (g)
BER14.5/6-1110GAFR	FR phenol	235	94V-0	5.50	27.2	0.4	0.55

*1 With 18.6kg/cm² force

*2 Minimum thickness of bobbin

ASSEMBLY

SURFACE MOUNT TYPE

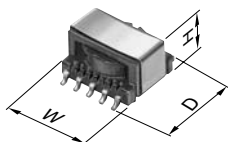

Dimensions in mm

W	15.1
D	16.2
H	7.3

ACCESSORIES

CLAMP

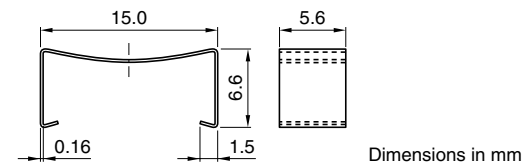

Part No.	Material	Weight (g)
FER14.5/6-A	Stainless steel	0.2

EE5 CORES

CORES

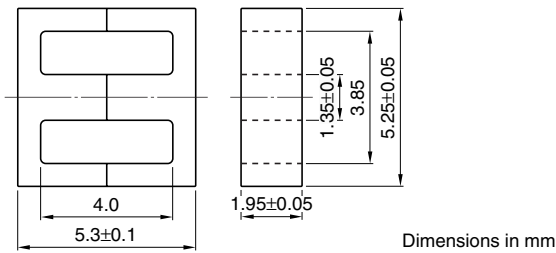

Parameter

Core factor	C ₁	mm ⁻¹	4.72
Effective magnetic path length	ℓ _e	mm	12.6
Effective cross-sectional area	A _e	mm ²	2.67
Effective core volume	V _e	mm ³	33.6
Cross-sectional center pole area	A _{cp}	mm ²	2.63
Minimum cross-sectional area	A _{cp min.}	mm ²	2.47
Cross-sectional winding area of core	A _{cw}	mm ²	5.0
Weight (approx.)		g	0.2

TYPICAL CHARACTERISTICS

Part No.	AL-value(nH/N ²) [1kHz, 0.5mA, 100Ts]	Core loss (W) [at 100°C]	
		100kHz 200mT	500kHz 50mT
PC44EE5-Z	200 min.		
H5C3EE5-Z*	980 min.		

* 10kHz, 10mV, 100Ts

BOBBINS

BE5-916FFR

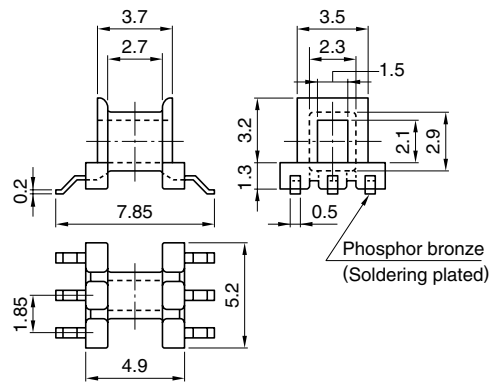

BE5-926FFR

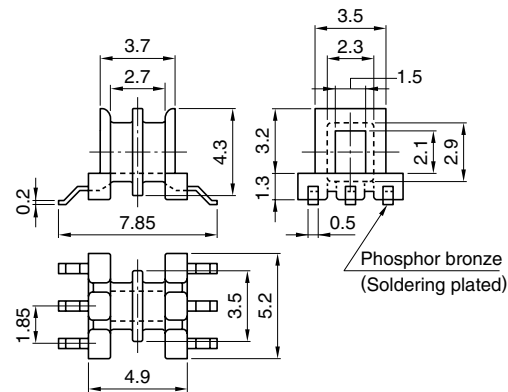

CONNECTING PIN PATTERNS

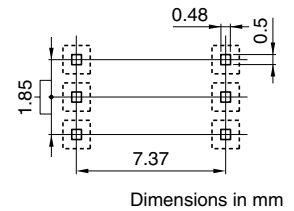

Part No.	Material	Heat deflection temperature (°C)*1	UL standard	Available winding cores section A _w (mm ²)	Average length of turns ℓ w(mm)	Minimum thickness t(mm)*2	Weight (g)
BE5-916FFR	Diallyphtalate	180	94V-0	1.62	12.4	0.4	0.03
BE5-926FFR	Diallyphtalate	180	94V-0	0.67×2	12.4	0.4	0.07

*1 With 18.6kg/cm² force

*2 Minimum thickness of bobbin

ASSEMBLY

SURFACE MOUNT TYPE

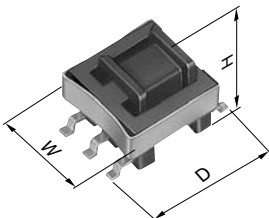

Dimensions in mm

W	5.7
D	7.8
H	4.8

ACCESSORIES

CLAMP

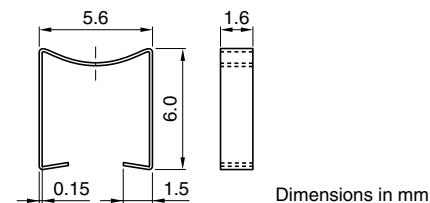

Part No.	Material	Weight (g)
FE-5-A	Stainless steel	0.04

EE8.9/8 CORES

CORES

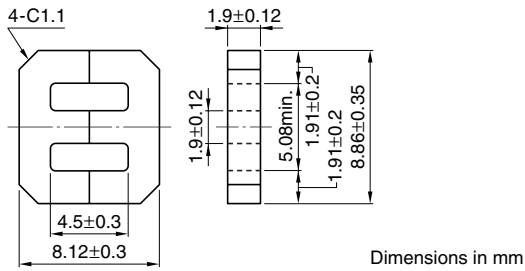

Parameter

Core factor	C ₁	mm ⁻¹	3.15
Effective magnetic path length	ℓ _e	mm	15.6
Effective cross-sectional area	A _e	mm ²	4.96
Effective core volume	V _e	mm ³	77.4
Cross-sectional center pole area	A _{cp}	mm ²	3.61
Minimum cross-sectional area	A _{cp min.}	mm ²	3.17
Cross-sectional winding area of core	A _{cw}	mm ²	7.07
Weight (approx.)		g	0.6

TYPICAL CHARACTERISTICS

Part No.	AL-value(nH/N ²) [1kHz, 0.5mA, 100Ts]	Core loss (W) [at 100°C]	
		100kHz 200mT	500kHz 50mT
PC44EE8.9/8-Z	480±25%	0.026	
H5C3EE8.9/8-Z*	2000 min.		

* 10kHz, 10mV, 100Ts

BOBBINS

BE8.9/8-118GFR

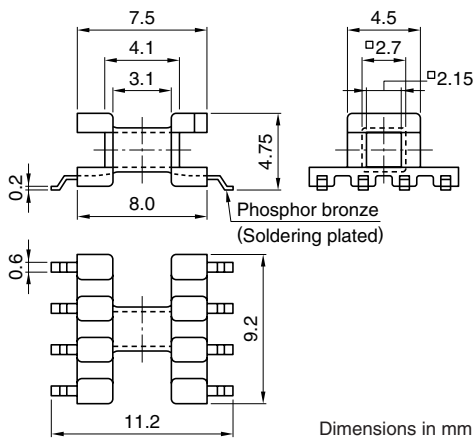

CONNECTING PIN PATTERNS

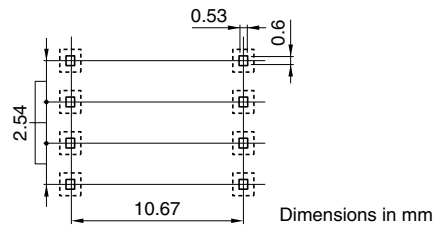

Part No.	Material	Heat deflection temperature (°C)*1	UL standard	Available winding cores section A _w (mm ²)	Average length of turns ℓ _w (mm)	Minimum thickness t(mm)*2	Weight (g)
BE8.9/8-118GFR	FR phenol	235	94V-0	2.79	14.4	0.275	0.17

*1 With 18.6kg/cm² force

*2 Minimum thickness of bobbin

ASSEMBLY

SURFACE MOUNT TYPE

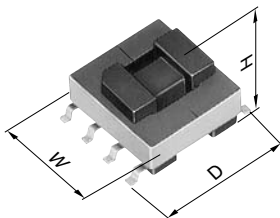

Dimensions in mm

W	9.3
D	11.3
H	4.75

EEM12.7/13.7 CORES

CORES

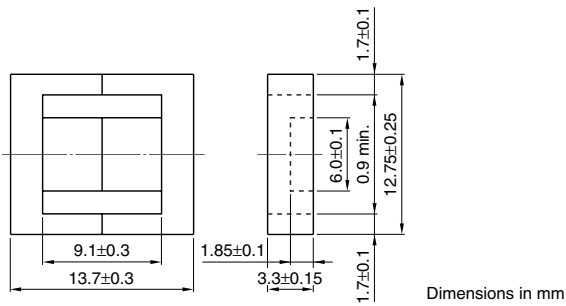

Parameter

Core factor	C ₁	mm ⁻¹	2.27
Effective magnetic path length	ℓ _e	mm	27.3
Effective cross-sectional area	A _e	mm ²	12.0
Effective core volume	V _e	mm ³	328
Cross-sectional center pole area	A _{cp}	mm ²	11.1
Minimum cross-sectional area	A _{cp min.}	mm ²	10.3
Cross-sectional winding area of core	A _{cw}	mm ²	15.2
Weight (approx.)		g	1.9

TYPICAL CHARACTERISTICS

Part No.	AL-value(nH/N ²) [1kHz, 0.5mA, 100Ts]		Core loss (W) [at 100°C]	
	Without air gap	With air gap	100kHz 200mT	500kHz 50mT
PC44EEM12.7/13.7-□□□□*1	820±25%	40±5% 63±7%	0.14	
PC50EEM12.7/13.7-□□□□	580±25%	40±5% 63±7%	0.038	
H5C3EEM12.7/13.7-Z*2	3000 min.			

*1 Including AL-value

*2 10kHz, 10mV, 100Ts

BOBBINS

BEM12.7-118GAFR

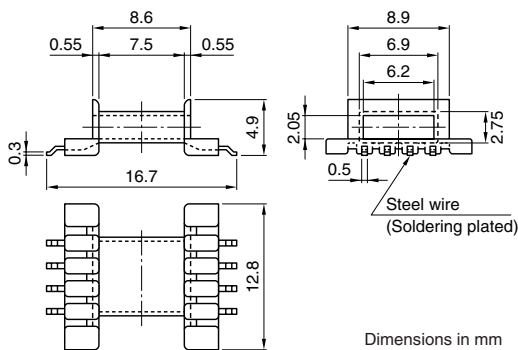

CONNECTING PIN PATTERNS

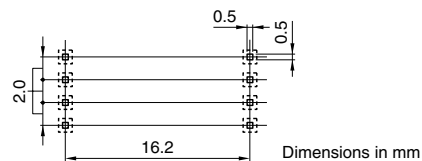

Part No.	Material	Heat deflection temperature (°C)*1	UL standard	Available winding cores section A _w (mm ²)	Average length of turns ℓ _w (mm)	Minimum thickness t(mm)*2	Weight (g)
BEM12.7-118GAFR	FR phenol	235	94V-0	7.5	22.4	0.35	0.31

*1 With 18.6kg/cm² force

*2 Minimum thickness of bobbin

ASSEMBLY

SURFACE MOUNT TYPE

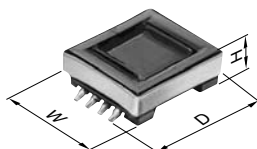

Dimensions in mm

W	13.55
D	16.8
H	5.0

ACCESSORIES

CLAMP

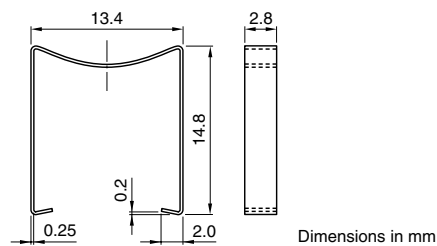

Part No.	Material	Weight (g)
FEM12.7/13.7-A	Stainless steel	0.25