

Dexter StackPack™

Stackable U-Cores



BENEFITS AT A GLANCE:

- > Standard off-the-shelf products
- > Immediate availability
- > Lower costs for than custom tooling or machining
- > Bobbins also available (as shown in picture)

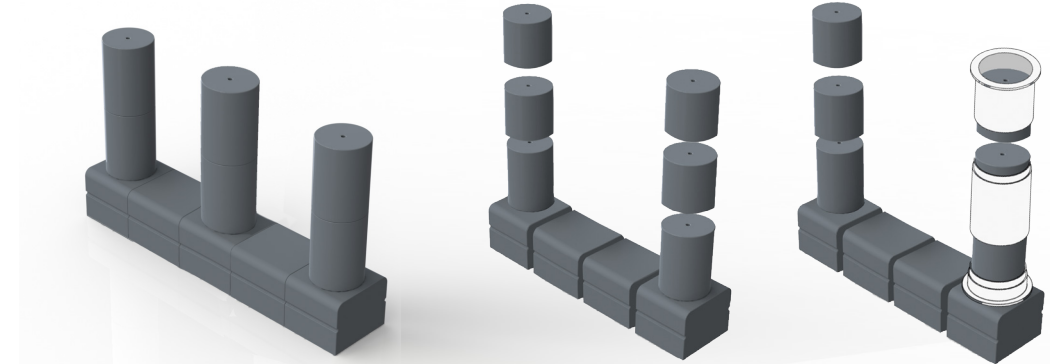

IN STOCK for immediate delivery:

EPCOS N87
EPCOS N49

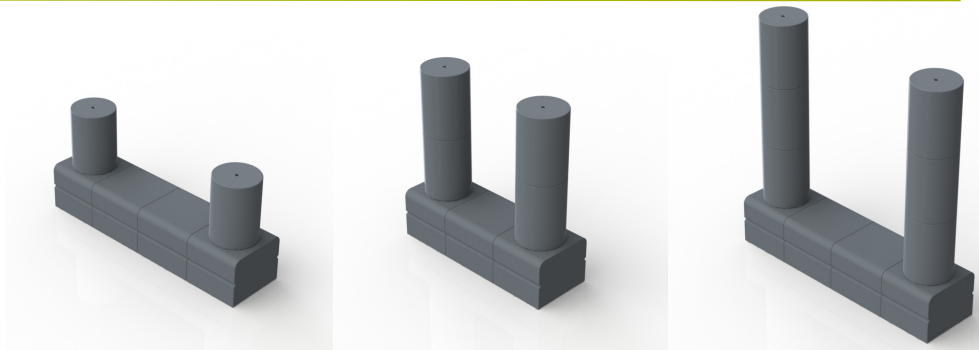

material available upon request:

EPCOS N92
EPCOS N95
EPCOS N97
EPCOS T65

LOOKING FOR FURTHER INFORMATION?

Chuck Wild at
cwild@dextermag.com
or (716) 864-1993

Chris Spadafora at
chris.spadafora@epcos.com
or (732) 906-4310

LEGACY OF SUPERIOR MAGNETIC DISTRIBUTION

Dexter Magnetic Technologies was founded at Permag Corporation in 1951 specifically to distribute magnetic materials to a broad base of customers and markets. The company continues to evolve its magnet offering with the launch of the StackPack™ modular core system from EPCOS brand ferrite products.

The new U-Core configuration is focused on meeting the needs of the High Voltage Transformer market and HF Filter applications by providing standard options which can fit any application need. The modular StackPack™ design offers flexibility and economy for designers.

System Benefits

- > Standard design offering multiple configurations
- > Lower cost than custom tooling or machining
- > Parts in stock for immediate assembly and shipment
- > Lower costs for rapid prototyping to prove out designs



Dexter StackPack™ Modular Core System

EXCLUSIVELY with EPCOS Stackable U-Cores

BENEFITS AT A GLANCE:

- > Standard off-the-shelf products
- > Immediate availability
- > Lower costs for than custom tooling or machining

Data Sheets are available on request.

Please contact
Chuck Wild or
Chris Spadafora

ABOUT DEXTER

Dexter Magnetic Technologies is the global architect in the specification, design and fabrication of magnetic products and assemblies. Since its founding in 1951, solutions designed by Dexter have and continue to positively impact our world daily – from life-saving medical devices to intelligent optics.

As the essential magnetic system partner, our teams of engineers and support staff are dedicated to delivering innovative technological solutions and services through a powerful combination of partnerships and superior engineering and manufacturing expertise.

Corner Part Number: B67410A0250X187 (N87 Material)
B67410A0250X149 (N49 Material)

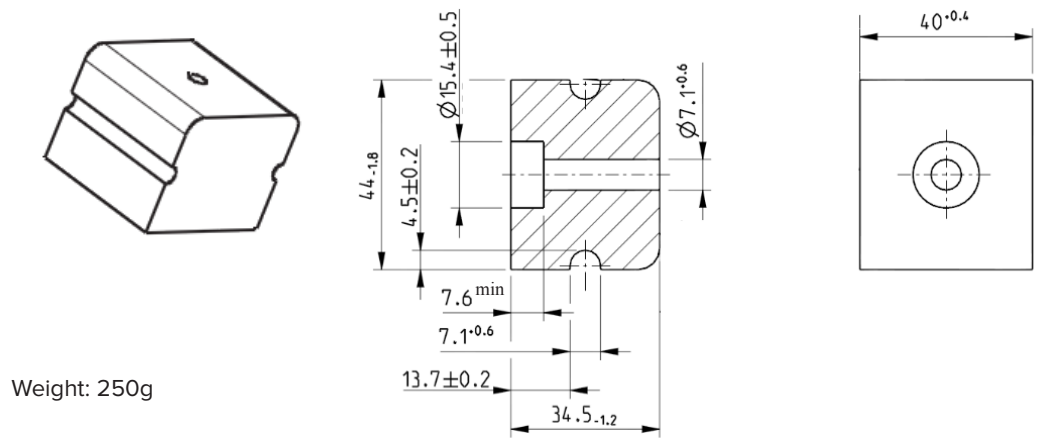

Weight: 250g

Leg Part Number: B62110A6018X087 (N87 Material)
B62110A6018X049 (N49 Material)

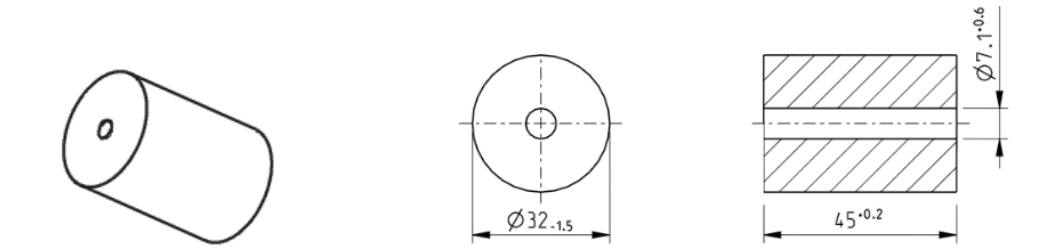

Weight: 160g

Spacer Part Number: B67410A0249X187 (N87 Material)
B67410A0249X149 (N49 Material)

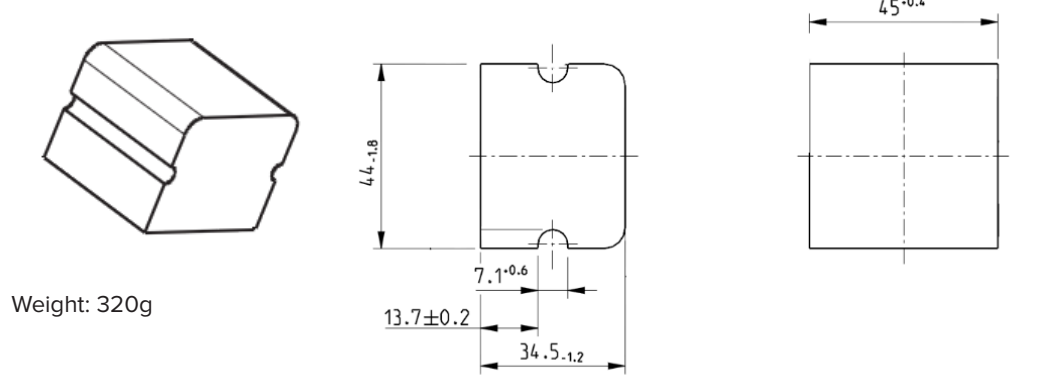

Weight: 320g

