

Magnetic Couplings in Medical Device Applications

Mike Schilling
Dexter Magnetic Technologies
Elk Grove Village, IL

Abstract

Magnetic technology has revolutionized the landscape of medical device applications, offering transformative solutions for diagnosis, treatment, and patient care. This paper explores the multifaceted role of magnetic technology in medical devices, encompassing diagnostic imaging, implantable devices, pain management, prosthetics, orthopedics, and surgical navigation. It examines the strategic integration of permanent magnets and electromagnetics in rotating equipment, highlighting their synergistic benefits in enhancing efficiency and reliability. Additionally, the paper provides an overview of magnetic coupling types and the importance of selecting the right magnetic component partner for device design, compliance, and manufacturability. Through collaboration and innovation, magnetic couplings empower medical device developers to create safer, more efficient, and reliable devices ultimately improving clinical outcomes and enhancing the quality of patient care in the healthcare industry.

An Overview of Magnetic Technology in Medical Devices

Magnetic technology has emerged as a transformative force within the realm of medical device products, revolutionizing various aspects of diagnosis, treatment, and patient care (Figure 1). Leveraging the unique properties of magnets, medical device manufacturers have engineered innovative solutions to address complex challenges in healthcare delivery. This overview explores the diverse applications of magnetic technology across a spectrum of medical devices, highlighting its profound impact on patient outcomes and clinical practices.

Diagnostic Imaging: One of the most prominent applications of magnetic technology in medicine is in diagnostic imaging modalities such as Magnetic Resonance Imaging (MRI). MRI utilizes powerful magnetic fields and radio waves to generate detailed

images of internal body structures, enabling healthcare professionals to diagnose a myriad of conditions ranging from neurological disorders to musculoskeletal injuries. The non-invasive nature of MRI, coupled with its high spatial resolution, has made it an indispensable tool for accurate diagnosis and treatment planning.



Figure 1: Medical Technology

Implantable Devices: Magnetic technology plays a pivotal role in the development of implantable medical devices, offering enhanced functionality and patient convenience. Devices such as magnetic resonance-compatible pacemakers and implantable cardioverter-defibrillators (ICDs) incorporate magnet-safe materials to ensure compatibility with MRI scans, allowing patients to undergo diagnostic procedures without the risk of device interference or malfunction. Furthermore, magnetic coupling mechanisms are utilized in implantable shunt valves, perfusion systems, ventricular assist devices, insulin pumps and drug delivery systems, facilitating precise dosage control and targeted therapy administration.

Pain Management: Transcranial Magnetic Stimulation (TMS) has emerged as a promising therapeutic modality for the treatment of neurological and psychiatric disorders, including depression, anxiety, and chronic pain. By delivering focused magnetic pulses to specific regions of the brain, TMS modulates neural activity and restores optimal brain function, offering a non-invasive alternative to traditional pharmacological interventions. Additionally, magnetic resonance-guided focused ultrasound (MRgFUS) is utilized for targeted pain management and tissue ablation procedures, providing patients with a safe and effective means of pain relief.

Prosthetics and Orthopedics: Magnetic technology has revolutionized the design and functionality of prosthetic and orthopedic devices, enhancing mobility and quality of life for individuals with limb loss or musculoskeletal impairments. Magnetic prosthetic attachments and orthopedic braces offer secure fixation and customizable adjustment, enabling patients to perform daily activities with greater comfort and confidence. Magnetic couplings are integrated into orthopedic reconstruction and bone growth applications. Moreover, magnetic levitation systems are employed in advanced prosthetic limbs to simulate natural movement patterns and optimize biomechanical performance.

Surgical Navigation and Robotics: Innovations in magnetic navigation systems and robotic-assisted surgery have transformed the landscape of modern surgical practice, enabling precision-guided procedures with enhanced safety and efficiency. Magnetic resonance-guided navigation systems provide real-time visualization and navigation capabilities during minimally invasive surgeries, facilitating precise instrument positioning and target localization. Robotic surgical platforms equipped with magnetic guidance systems offer surgeons unparalleled control and dexterity, enabling complex procedures with reduced risk of complications and improved patient outcomes. Magnetic gripping and holding, sensors, encoders, motors and couplings are key components in surgical robotic applications.

In summary, the integration of magnetic technology into medical device products has catalyzed a paradigm shift in healthcare delivery, empowering clinicians with advanced tools and techniques for diagnosis, treatment, and patient care. As research and innovation continue to advance, the potential applications of magnetic technology in medicine are boundless, promising new avenues for improved clinical outcomes and enhanced patient experiences.

The Role of Permanent Magnets (PM) and Electromagnetics in Rotating Equipment

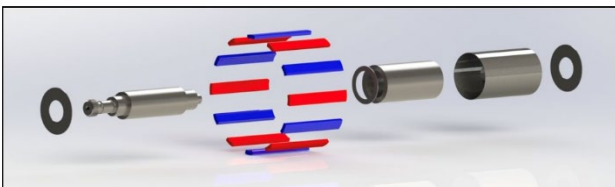

Figure 2: Sleeved PM Rotor

Rotating equipment is ubiquitous across various industries, ranging from the highly regulated medical and aerospace sectors to energy generation and automotive. The efficient operation of these systems often relies on the strategic integration of magnetic technologies, including permanent magnets and electromagnetics. In this overview, we explore the applications of each technology individually and their synergistic combination in rotating equipment.

Permanent Magnets in Rotating Equipment:

Rare earth permanent magnets play a pivotal role in enhancing the performance and efficiency of rotating equipment (Figure 2). Their unique properties, such as high coercivity and remanence, make them ideal for applications where continuous magnetic fields are required without the need for external power sources.

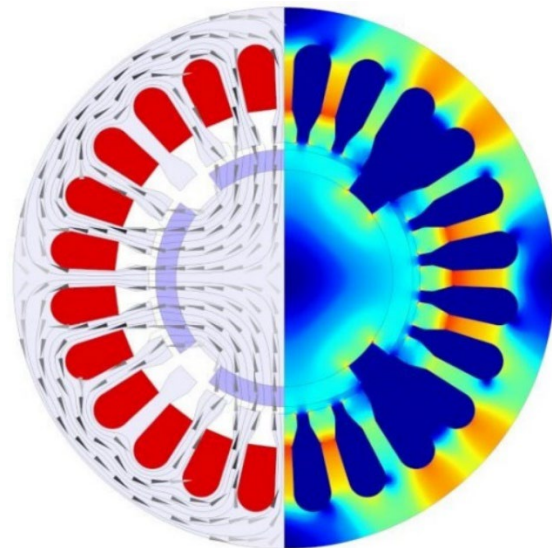

Figure 3: PM Motor Simulation

Credit: Integrated Engineering Software

In the realm of rotating equipment, permanent magnets find extensive use in various devices, including:

Electric motors and generators: PM motors and generators offer significant advantages over conventional counterparts in terms of higher power density, improved efficiency, and reduced size and weight (Figure 3). They are widely employed in applications ranging from industrial machinery to electric vehicles, where compactness and energy efficiency are paramount.

Magnetic Bearings: PM and hybrid magnetic bearings provide frictionless support to rotating shafts, thereby eliminating the need for traditional lubrication systems (Figure 4). These bearings offer low maintenance requirements, reduced energy consumption, and enhanced reliability, making them suitable for high-speed rotating equipment such as turbines, compressors, VADs and perfusion pumps.

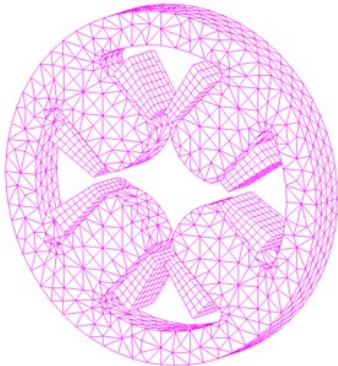

Figure 4: Magnetic Bearing Simulation
Credit: Integrated Engineering Software

Magnetic Couplings: In rotating equipment where hermetic sealing is crucial, such as pumps and mixers handling corrosive fluids, magnetic couplings facilitate torque transmission without physical contact between the driving and driven shafts. PM-based couplings ensure leak-free operation, preventing contamination and minimizing downtime.

Application of Electromagnetics in Rotating Equipment:

Electromagnetic technologies offer unparalleled flexibility and controllability in rotating equipment, enabling precise modulation of magnetic fields to meet diverse operational requirements. Key applications of electromagnetics in rotating equipment include:

Electromagnetic Brakes and Clutches:

Electromagnetic brakes and clutches provide adjustable torque transmission capabilities, allowing for smooth engagement and disengagement in machinery such as conveyors, printing presses, and machine tools. By regulating the applied current, operators can precisely control the braking or clutching action, enhancing safety and operational efficiency.

Eddy Current Dampers: Eddy current dampers harness electromagnetic principles to mitigate undesirable vibrations and oscillations in rotating equipment. By inducing opposing currents in conductive materials, eddy

current dampers dissipate mechanical energy, resulting in improved stability and reduced noise levels in systems such as turbines and centrifuges.

Electromagnetic Actuators: In applications requiring precise positioning or motion control, electromagnetic actuators offer responsive and accurate performance. Whether in valve actuators for flow control systems or in robotic manipulators for surgical robotics, electromagnetically driven actuators enable dynamic response and adaptability to changing operating conditions.

Combination of Permanent and Electromagnetic Technology in Rotating Equipment:

The fusion of permanent magnets and electromagnetics presents a compelling proposition for optimizing the performance and functionality of rotating equipment. By capitalizing on the strengths of both technologies, engineers can achieve synergistic benefits such as:

Hybrid Motor Designs: Hybrid motor configurations incorporate both permanent magnets and electromagnetics to capitalize on the high torque density of permanent magnets and the controllability of electromagnetic windings. This approach enables superior efficiency and dynamic response, making it well-suited for applications demanding precise speed and torque regulation.

Variable Flux Machines: By combining permanent magnet rotors with electromagnetically controlled stator windings, variable flux machines offer the flexibility to adjust the magnetic flux density during operation. This adaptability allows for optimal performance across a wide range of operating conditions, enhancing the versatility and efficiency of rotating equipment in diverse applications.

The strategic integration of permanent magnets and electromagnetics in rotating equipment underscores the pivotal role of magnetic technologies in driving innovation and efficiency across industries. By leveraging the complementary strengths of these technologies, engineers can unlock new possibilities in design, performance, and functionality, shaping the future of rotating equipment in the global marketplace.

Overview of Magnetic Coupling Types

Type 1 - Synchronous Couplings

Permanent Magnet Synchronous Couplings represent a breakthrough in mechanical power transmission, offering efficient and reliable torque or linear force transfer without the need for direct mechanical contact between the driver and driven members (Figure 5). This technology finds extensive applications across various industries due to its versatility, precision, and reliability.

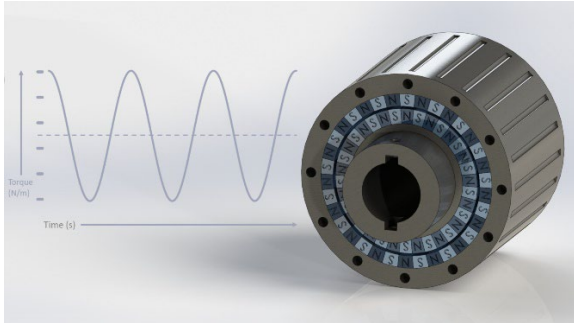

Figure 5: Synchronous Coupling Torque vs Angle



Figure 6: Synchronous Coupling Components

Torque and Linear Motion Transfer via the Coupling of Magnetic Fields

Synchronous couplings operate on the principle of magnetically coupling the driver and driven elements, allowing for the transfer of torque in rotary or force in linear motion applications without physical contact. This is achieved through the establishment of a magnetic field between the driver and driven elements, enabling seamless transmission of power (Figure 6).

As the name implies, this coupling is a synchronous version that inherently results in a 1:1 relationship between the motion of the driver and follower. Our early experiences with magnets taught us that like magnetic poles (North-North and South-South) repel each other while opposite poles (North-South) attract, synchronous

couplings exploit these “attractive” and “repulsive” characteristics to produce motion. By placing an array of alternating pole permanent magnets (N-S-N-S) on the driver and an equivalent array of alternating pole permanent magnets on the follower, a “coupled” magnetic circuit is produced with each North and South pole in the driver linked to each respective South and North pole of the follower.

As an angular displacement is introduced between the driver and the follower, the magnet poles start to overlap one another, the relative “attraction” and “repulsion” lead to a “push-pull” effect and consequent motion. The magnitude of the resultant force depends not only on the amount of overlap, but also on the chosen magnetic material’s characteristics and separation distance between the driver and follower. The effective air gap between the driver and driven elements plays a critical role in synchronous coupling efficiency. A smaller air gap enhances magnetic coupling strength, resulting in more efficient power transmission and improved performance. Another factor is the number of pole pairs in the synchronous coupling directly influences its magnetic stiffness. Increasing the number of pole pairs enhances stiffness, improving the coupling’s ability to withstand torsional loads and maintain stability during operation. The optimum number of poles is determined by the effective air gap and special requirements.

At some displacement, however, the peak force producing capabilities of the coupling are achieved. Displacement beyond this point results in a decoupling. This decoupling manifests itself as a ratcheting action resulting from like magnetic poles of the driver and follower repelling each other. Unlike its mechanical equivalent, however, the decoupling does not, generally, lead to permanent damage; and synchronization is reinitiated at the next magnetic pole coupling point (Figure 5).

Synchronous coupling benefits include:

Accommodation of Shaft Misalignments in Rotary Applications: Synchronous couplings excel in accommodating slight misalignments between input and output shafts, particularly in rotating applications such as seal-less pumps. This capability reduces wear and tear on the system, enhancing longevity and reliability.

The Ability to Introduce a Non-Magnetic Containment Barrier

Figure 7: Synchronous Coupling Barrier Options

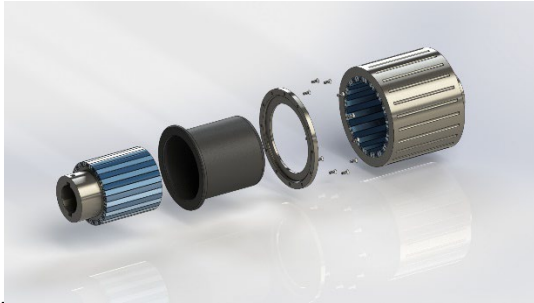

Plastic

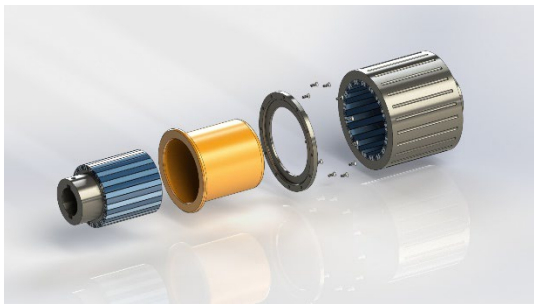

Ceramic

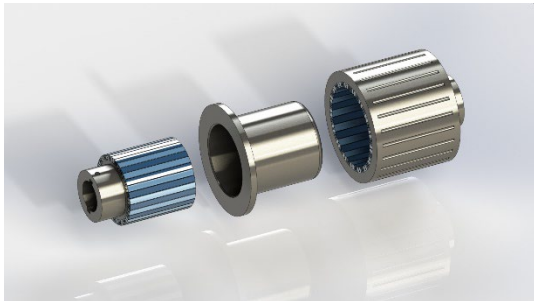

Metallic

By incorporating non-magnetic containment barrier materials, synchronous couplings eliminate the need for mechanical seals, thereby isolating the processing environment from external factors. This enhances safety, reduces maintenance requirements, and prevents contamination in critical applications. Careful consideration of materials is required. Considerations can include pressure capability, chemical and biocompatibility. The use of electrically conductive containment barrier materials in synchronous couplings can introduce eddy current power losses. Proper design considerations are crucial to mitigate these losses and optimize system efficiency.

Overload and Torque Protection: Synchronous couplings offer built-in overload and torque protection mechanisms, safeguarding equipment and ensuring optimal performance under varying operating conditions. This feature enhances system reliability and prevents damage to components.

Additional considerations:

Temperature Effects on Magnets and Peak Torque: Temperature fluctuations can affect the performance of **magnets used in synchronous couplings and impact peak torque capabilities.** Proper thermal management is essential to maintain optimal operating conditions and prolong the lifespan of the coupling system.

Synchronous couplings find diverse application across industries, including the following medical device applications:

- Seal-less centrifugal pumps in perfusion systems
- Ventricular assist devices (VADs)
- Gas mixing fans in excimer lasers
- Vacuum robots
- Magnetically coupled laboratory mixers
- Torque limiters in surgical tools and robotics
- Transcutaneous torque transfer in implantable drain valves and limb lengthening devices

Synchronous couplings represent a revolutionary advancement in mechanical power transmission, offering enhanced efficiency, reliability, and precision across a wide range of applications. With their unique capabilities and versatile design, synchronous couplings continue to drive innovation and improve operational performance in various fields.

Type 2 - Eddy Current Couplings

Eddy current couplings, also known as eddy current drives or clutches, are innovative devices utilized in various applications to transfer torque or induce linear motion without the need for mechanical contact between the driver and driven members. They rely on the principle of electromagnetic induction to achieve efficient and precise power transmission (Figure 8). Let's delve into the intricacies of rotary and linear eddy current couplings.

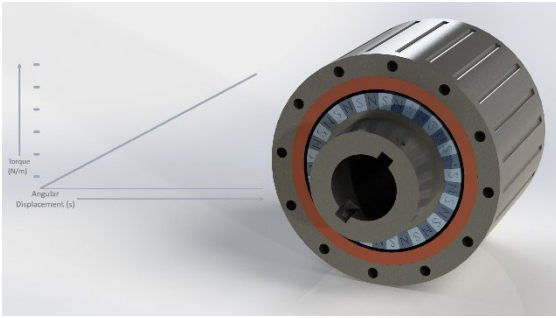

Figure 8: Eddy Current Coupling Torque vs Differential Speed



Figure 9: Eddy Current Coupling Components

Transfer Torque, Induce Linear Motion or Braking:

This coupling is an asynchronous version that relies on a speed mismatch between the driver and follower to produce a force. An array of alternating pole permanent magnets (N-S-N-S) is placed on either the driver or follower, and an electrically conductive material (typically aluminum or copper) is placed on the mating component. (Figure 9)

Eddy current couplings operate by inducing magnetic fields into an electrically conductive element, typically a disk, rotor, tube or plate (Figure 10). The induced currents in the conductive element create a counter magnetic field that couples with the field of the driver magnets, this results in torque, linear motion or braking. Amperes Law governs the relationship between the induced electric and resultant magnetic fields.

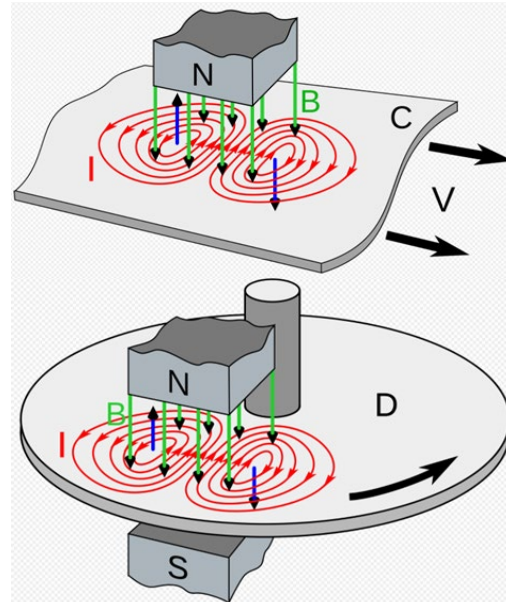

Figure 10: Eddy Current Effect: Linear and Rotary

The force generated by eddy currents between a magnet and a conductive plate can be calculated using the following basic formula:

$$F = (RK \times B^2 \times d^2 \times V) / R$$

Where:

- *F* is the force generated by the eddy currents.
- *K* is a constant depending on the geometry of the magnet and the conductor.
- *B* is the magnetic field strength of the magnet.
- *d* is the distance between the magnet and the conductive plate.
- *V* is the volume of the magnet.
- *R* is the electrical resistance of the conductor.

This formula provides a basic estimation of the eddy current force. However, please note that the actual force can be influenced by various factors including the shape of the magnet and the conductor, the frequency of the magnetic field, and the specific properties of the materials involved. Additionally, in practical applications, more complex models and simulations may be required to accurately predict the eddy current force.

To introduce the dependency on speed in the calculation of eddy current force between a magnet and a conductive plate, we need to consider Faraday's law of electromagnetic induction, which states that a changing

magnetic field induces an electromotive force (EMF) in a conductor.

When the magnet moves relative to the conductive plate, the magnetic field experienced by the plate changes, inducing eddy currents. The rate of change of the magnetic field, which is influenced by the speed of movement, affects the magnitude of the induced currents and consequently the force exerted on the plate.

To incorporate speed into the formula, we can use the concept of induced voltage (V_{ind}) due to the relative motion between the magnet and the conductor. The induced voltage is given by:

$$V_{ind} = B \times v \times l$$

Where:

- B is the magnetic field strength.
- v is the relative velocity between the magnet and the conductor (speed).
- l is the characteristic length of the conductor.

The characteristic length l is typically the length of the conductor in the direction of motion.

The force F due to the eddy currents can then be expressed as:

$$F = RK \times B \times v \times l \times d \times V$$

Incorporating the speed parameter v into the formula allows for a more accurate representation of the dynamics involved in the interaction between the magnet and the conductive plate. This revised formula accounts for the impact of speed on the generation of eddy currents and subsequently on the force exerted between the magnet and the conductor.

Unlike the synchronous couplings, this asynchronous version is a “lossy” device and prone to Ohmic loss heating that results from the induced electric currents.

Accommodation of Misalignments:

Rotary eddy current couplings can accommodate slight misalignments in input and output shafts, making them suitable for rotating applications where precise alignment may be challenging.

Impact of Temperature:

Temperature can affect the performance of the permanent magnets and the maximum torque capacity of eddy current couplings. Proper thermal management is crucial to maintain optimal performance.

Applications:

Vibration Damping:

Linear eddy current couplings offer vibration damping capabilities, making them ideal for applications requiring smooth and controlled linear motion.

Thread and Web Tensioning:

Rotary eddy current couplings excel in thread and web tensioning applications, providing precise control over tension levels for improved production quality.

Braking:

Both rotary and linear eddy current couplings can be utilized for braking purposes, offering efficient and adjustable, contactless braking mechanisms.

Advantages/Disadvantages:

Advantages:

Long and reliable lifespan due to absence of mechanical contact.

Smooth adjustment of output torque and speed provides precise control over operations.

Disadvantages:

Typically designed for specific speed differentials (10-30%) due to considerations of efficiency and cooling requirements. The “Lossy” nature of the device may require active cooling, reduced volumetric force density.

In conclusion, eddy current couplings represent a sophisticated solution for precise torque transfer and motion control in medical settings. Their versatility and reliability make them invaluable assets in modern medical device engineering applications.

Type 3 - Hysteresis Couplings

Hysteresis couplings are innovative devices used in various applications, particularly in scenarios where precise torque transfer or smooth linear motion is essential. They operate on the principle of inducing magnetic fields into a specialized magnetic hysteresis alloy, facilitating torque transmission or linear motion without direct mechanical contact between the driving and driven components.

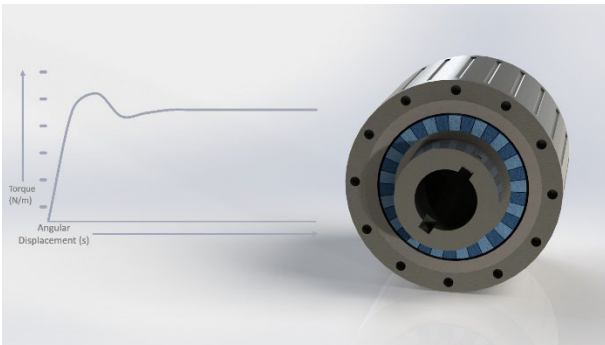

Figure 11: Hysteresis Coupling Torque vs Differential Speed



Figure 12: Hysteresis Coupling Components

This coupling is typically used in an asynchronous fashion. An array of alternating pole permanent magnets (N-S-N-S) is placed on either the driver or follower, and an easily magnetized/demagnetized material known as Hysterloy is placed on the mating component. At rest, the permanent magnet array is designed to magnetize the Hysterloy, resulting in a synchronously coupled magnetic circuit*. Should these forces suffice for the application, this coupling will operate in a synchronous state.

**The volumetric force density can be orders of magnitude lower than the Class 1 coupling due to the magnetic characteristics of the Hysterloy.*

This eliminates mechanical contact, ensuring a maintenance-free and wear-resistant operation.

To calculate the hysteresis force generated between a moving permanent magnet and a soft magnetic plate, you can use a simplified formula based on the energy loss due to hysteresis. The hysteresis force is a result of the energy dissipation caused by the repeated magnetization and demagnetization cycles of the soft

magnetic material as it interacts with the moving permanent magnet.

The basic formula to calculate the hysteresis force F_h is:

$$F_h = k \times V \times B_m \times f$$

Where:

- k is a constant depending on the material properties and the geometry of the system.
- V is the volume of the soft magnetic material.
- B_m is the maximum magnetic flux density of the permanent magnet.
- f is the frequency of the magnetization cycles.

Please note that this formula provides a basic approximation and might not capture all the complexities of the hysteresis phenomenon. Also, the constant k could be determined experimentally or obtained from empirical data or simulations for specific materials and configurations.

For more accurate calculations, especially in practical applications, finite element analysis (FEA) or specialized software tools may be required to model the magnetic interactions and hysteresis effects more comprehensively. These methods can provide detailed insights into the behavior of magnetic systems under various conditions and geometries.

Impact of Changing Magnetic Field Frequency: At lower speeds, the rotational drag is constant and not dependent on speed. At higher speeds, the torque or force transfer in a hysteresis coupling is influenced increasing frequency of the changing magnetic field. Higher frequencies can induce eddy current losses in conductive hysteresis alloys. The superimposed eddy current losses combine with the hysteresis losses. At some point, the eddy current loss can result in reduced torque transfer efficiency due to heating within the hysteresis material. Temperature effects on the hysteresis elements performance requires a detailed analysis by the designer.

Effect of Effective Air Gap: The effective air gap between the driver and driven elements significantly impacts the performance of hysteresis couplings. A smaller air gap enhances torque transmission efficiency by reducing magnetic reluctance.

Pole Pairs and Magnetic Stiffness: The number of pole pairs in a hysteresis coupling directly impacts its magnetic stiffness. Optimization of the number of pole

pairs is important to maximize the efficiency of the coupling's performance.

Accommodation of Misalignments: In rotary applications, magnetic hysteresis couplings can accommodate slight misalignments between input and output shafts. This flexibility ensures smooth operation even in imperfect alignment scenarios.

Smooth Torque Limiting in Linear Hysteresis Couplings: Linear hysteresis couplings are adept at providing smooth torque limiting, ensuring controlled motion and preventing sudden jerks or overloads in linear motion applications.

Applications: Hysteresis couplings find primary application in low-speed scenarios with frequent or permanent slipping, including filling and bottle capping plants, winding and unwinding equipment, as well as medical and materials handling technology. Their reliability and precise torque transfer make them indispensable in such environments.

In summary, hysteresis couplings represent a sophisticated solution for diverse torque and linear motion transmission needs, offering reliability, efficiency, and adaptability across various medical applications.

The Importance of Selecting the Correct Magnetic Component Partner

Novel Magnetic Design for Size Reduction and Efficiency Improvements

Innovative magnetic designs have the potential to revolutionize the size and efficiency of medical devices. By collaborating with the right magnetic component partner, medical device developers can leverage cutting-edge technologies to optimize device size and energy efficiency, ultimately improving patient outcomes and clinical workflows.

Protection of Magnets and Ferrous Components

Ensuring the longevity and performance of medical devices necessitates robust protection against corrosion and chemical exposure. Partnering with a magnetic component supplier that specializes in advanced materials and coatings enables developers to safeguard magnets and ferrous components, enhancing device durability and reliability in clinical settings.

ISO 10993 Regulatory Requirements and Biocompatibility

Compliance with ISO 10993 regulatory standards for biocompatibility is paramount in medical device design and manufacturing. Magnetic component partners with expertise in biocompatible materials and testing protocols can assist developers in navigating regulatory requirements, ensuring the safety and efficacy of medical devices for patient use.

Containment Barrier Selection and Hydraulic Analysis

The selection of containment barriers and hydraulic analysis are critical aspects of medical device design, particularly in applications involving fluid handling and pressure regulation. Through computational fluid dynamics (CFD) analysis and material selection expertise, magnetic component partners can help optimize containment barrier design, minimize hydraulic losses, and enhance device performance and reliability.

Managing Stray Magnetic Fields and EMF Interactions

The presence of stray magnetic fields and electromagnetic interference (EMI) poses challenges in medical device integration and operation. Collaborating with magnetic component partners that specialize in EMI shielding and mitigation techniques enables developers to effectively manage stray magnetic fields, ensuring compatibility with other medical devices and minimizing potential risks to patient safety and device functionality.

Early Involvement with Suppliers for Design for Manufacturability

Early involvement with magnetic component suppliers is key to optimizing the design, manufacturability, and cost-effectiveness of medical devices. By collaborating with suppliers from the early stages of development, medical device developers can leverage design for manufacturability (DFM) principles to streamline production processes, reduce time-to-market, and enhance the overall quality and performance of medical devices.

Conclusion

In conclusion, the strategic selection and utilization of magnetic couplings in medical device applications represent a paradigm shift in healthcare innovation. By partnering with the right magnetic component supplier, medical device developers can harness the full potential of magnetic technology to drive advancements in diagnosis, treatment, and patient care. Through a holistic approach to design, regulatory compliance, and

manufacturability, magnetic couplings empower developers to create safer, more efficient, and more reliable medical devices that improve clinical outcomes and enhance the quality of patient care.

References:

1. Smith, H. J., & Ranallo, F. N. (2011). MRI: Basic Principles and Applications. Wiley-Blackwell.
2. Brown, M. A., & Semelka, R. C. (2010). MRI: Basic Principles and Applications. Wiley-Liss.
3. Nazarian, S., & Roguin, A. (2013). Imaging in Patients with Cardiac Devices. *Circulation: Arrhythmia and Electrophysiology*, 6(2), 419-428.
4. Kalin, R., & Stanton, M. S. (2005). Current Clinical Issues for MRI Scanning of Pacemaker and Defibrillator Patients. *Pacing and Clinical Electrophysiology*, 28(4), 326-328.
5. George, M. S., & Aston-Jones, G. (2010). Noninvasive Techniques for Probing Neurocircuitry and Treating Illness: The National Institute of Mental Health Workshop. *Biological Psychiatry*, 68(2), 197-204.
6. Lefaucheur, J. P. (2019). Transcranial Magnetic Stimulation. *Handbook of Clinical Neurology*, 160, 559-580.
7. Herr, H. M. (2009). Exoskeletons and Orthoses: Classification, Design Challenges and Future Directions. *Journal of NeuroEngineering and Rehabilitation*, 6(1), 21.
8. Vickers, R. J., & Baldwin, M. A. (2016). Magnetic Levitation Technology and Applications. *IEEE Transactions on Magnetics*, 52(7), 1-12.
9. Cleary, K., & Peters, T. M. (2010). Image-Guided Interventions: Technology and Applications. Springer.
10. Satava, R. M. (2002). Emerging Technologies for Surgery in the 21st Century. *Archives of Surgery*, 137(1), 60-64.
11. Campbell, P. (1994). Permanent Magnet Materials and Their Application. Cambridge University Press.
12. Jahns, T. M. (2001). Improved Reliability in PM Machine Drives. *IEEE Transactions on Industry Applications*, 37(5), 1308-1315.
13. Müller, A., & Lang, S. (2012). Magnetic Couplings for High-Efficiency Contactless Power Transfer. *IEEE Transactions on Magnetics*, 48(3), 1109-1112.
14. Zhu, Z. Q., & Howe, D. (2007). Electrical Machines and Drives for Electric, Hybrid, and Fuel Cell Vehicles. *Proceedings of the IEEE*, 95(4), 746-765.
15. Jackson, R. S., & Srinivasan, V. (2017). Designing for Manufacturability: A Systems Approach to Concurrent Engineering. CRC Press.
16. Pahl, G., Beitz, W., Feldhusen, J., & Grote, K. H. (2007). Engineering Design: A Systematic Approach. Springer.
17. Griffiths, D. J. (1999). Introduction to Electrodynamics (3rd ed.). Prentice Hall. This textbook provides a comprehensive introduction to electromagnetic induction, including Faraday's law and its implications for induced currents and voltages.
18. Lenz, W. (1882). Electromagnetic Phenomena in *Annalen der Physik*. Lenz's law, which describes the direction of induced currents, is foundational for understanding eddy currents.
19. Reitz, J. R., Milford, F. J., & Christy, R. W. (2008). Foundations of Electromagnetic Theory (4th ed.). Addison-Wesley. This book covers the theoretical underpinnings of eddy currents and the forces they generate.
20. Kraus, J. D., & Carver, K. R. (1990). Electromagnetics (2nd ed.). McGraw-Hill. This text is a good resource for understanding practical applications of electromagnetic principles, including eddy currents.
21. Plonus, M. A. (1978). Applied Electromagnetics. McGraw-Hill. This book provides insights into the practical aspects of electromagnetics, including the effects of motion on magnetic fields and induced forces.
22. A. J. Baden Fuller (1990). "Eddy Currents in Magnetic Materials," in *IEEE Transactions on Magnetics*, vol. 26, no. 2, pp. 522-528. This paper discusses the impact of eddy currents in various materials and configurations.

23. P. S. Keatley, et al. (2011). "Dynamics of Magnetic Vortex Cores in Single Permalloy Disks," in Physical Review B, vol. 84, no. 18. This article explores the behavior of eddy currents in magnetic materials under dynamic conditions.

24. "Magnetic Materials: Fundamentals and Applications" by Nicola A. Spaldin - This book covers the fundamentals of magnetic materials, including the principles of hysteresis and the interactions between permanent magnets and soft magnetic materials.

25. "Introduction to Magnetism and Magnetic Materials" by David C. Jiles - This textbook provides an in-depth look at the properties of magnetic materials, including hysteresis effects and their applications.

26. "Electromagnetic Theory" by Julius Adams Stratton - This classic text delves into the theoretical aspects of electromagnetism, including magnetic forces and hysteresis.

27. "Magnetic Hysteresis" by Edward Della Torre - This book specifically focuses on hysteresis phenomena in magnetic materials, providing both theoretical and practical insights.

28. "Finite Element Analysis of Magnetic Systems" by S. S. Rao - This reference discusses the application of finite element analysis in modeling magnetic systems, which can be used to study hysteresis forces in detail.